

SWR – Basic 9” Wrap

Have a school relighting project where you need to maintain a traditional look and feel?

- The SWR is the classic school room or utility fixture with all the modern features you need.
- Cost effective....
- Energy Efficient components....
- Labor saving bulk packaging....
- Excellent optics for task lighting....
- More aesthetically pleasing than most “off the shelf” wraps.
- Light weight construction suitable for surface or suspended mounting.
- Meets efficiency standards for many energy rebates when utilized with enhanced aluminum reflector.

In a fast moving world speed is everything.

- Let our quickness and flexibility be your competitive edge.
- Quick turn around times for both quoting and configured to order delivery will help you outshine your competitors.
- P2 is committed to making sure you have what you need, when you need it.

SWR – Basic 9” Wrap



Application

- Suitable for a variety of general educational and retail applications.
- Configured to order with the latest energy efficient lamps and ballasts.
- Great for replacing outdated T12 fixtures found in many schools.

SWR – 1x4 – 3L – T8 – UL1 – LP – IS – UE – EB



Fixture Series

SWR = Basic Wrap

Fixture Size

1x4 = 1x4 Nominal
1x8 = 1x8 Nominal

Lamp Qty

1L = One Lamp
2L = Two Lamps
3L = Three Lamps
4L = Four Lamps
6L = Six Lamps

Lamp Type

T8 = Linear T8 Lamps

Voltage (1)

UL1 = Universal 120-277
UL2 = Universal 120-277
UH1 = Universal 347-480
UH2 = Universal 347-480
120 = 120 Volt Dedicated
277 = 277 Volt Dedicated
347 = 347 Volt Dedicated

Ballast Factor (2)

XL = Ultra Low Power (.62 - .66)
LP = Low Power (.75 - .78)
MP = Mid Power (.85 - .88)
MN = Neutral Power (.97 - 1.04)
HP = High Power (1.15 - 1.20)

Ballast Starting Method

PS = Programmed Start
IS = Instant Start
PSD = Program Start Step Dimming
ISD = Instant Start Step Dimming
PVD = Program Start 0-10v Variable Dim
IVD = Instant Start 0-10v Variable Dim

T8 Ballast Grade

ST = Standard Grade
UE = Ultra Efficient T8

Other Options

SB = Specific Ballast Type or Manufacturer (3)
EB = Emergency Battery Backup (3)

Numeric Footnotes

(1) Numeral indicates number of ballasts per fixture.

(2) Ballast factors outside ranges shown to be called out numerically.

(3) If SB or EB is requested, purchaser must identify the ballast manufacturer and the catalog number.

SWR – Basic 9" Wrap

Fixture Construction

- Available in 1, 2, or 3 lamp cross sections, and in a variety of in-line tandem wired configurations for row lighting applications.
- Can be surface mounted or suspended with factory installed hanging brackets.
- Ballast and reflector material made to customer specifications.
- Lightweight body for ease of installation
- Tool-less access to lamps and ballast allowing for ease of installation and maintenance.
- Prismatic acrylic wrap lens.

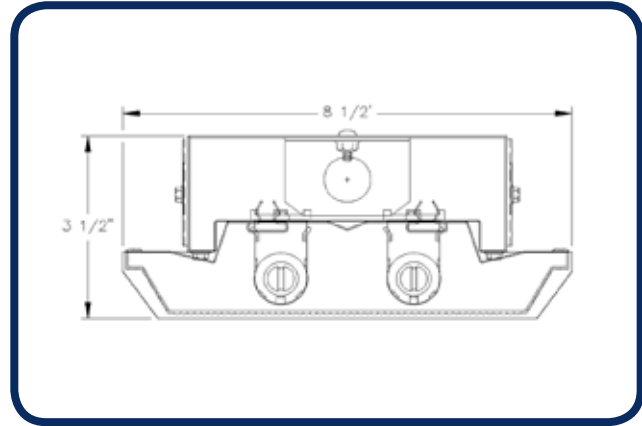

Existing Systems

Existing Lamp / Ballast System	Lamp Quantity & Type	Mean Lumens Per Lamp	Mean Lumens Per Fixture	Ballast Factor	Net Lumens Per Fixture	Input Watts	Net Lumens Per Watt
2L40-T12 Mag	2 F40/T12/WM	2,280	4,560	0.88	4,013	72	56
3L40-T12 Mag	3 F40/T12/WM	2,280	6,840	0.88	6,019	115	52
4L40-T12 Mag	4 F40/T12/WM	2,280	9,120	0.88	8,026	144	56
1L96-T12 Mag	1 F96/T12/ES	4,750	4,750	0.88	4,180	76	55
2L96-T12 Mag	2 F96/T12/ES	4,750	9,500	0.88	8,360	126	66
1L96-T12HO Mag	1 F96/T12HO/ES	6,950	6,950	0.95	6,603	125	53
2L96-T12HO Mag	2 F96/T12HO/ES	6,950	13,900	0.93	12,927	210	62

Re-Lighting Options

Proposed Lamp / Ballast System	Lamp Quantity & Type	Mean Lumens Per Lamp	Mean Lumens Per Fixture	Ballast Factor	Net Lumens Per Fixture	Input Watts	Net Lumens Per Watt
2L32-T8-LP Elec	2 F32T8/841	2,800	5,600	0.77	4,312	48	90
2L32-T8-MP Elec	2 F32T8/841	2,800	5,600	0.87	4,872	53	92
3L32-T8-LP Elec	3 F32T8/841	2,800	8,400	0.77	6,468	72	90
3L32-T8-MP Elec	3 F32T8/841	2,800	8,400	0.87	7,308	80	91
4L32-T8-LP Elec	4 F32T8/741	2,660	10,640	0.77	8,193	96	85
4L32-T8-MP Elec	4 F32T8/741	2,660	10,640	0.87	9,257	107	87
6L32T8-MP Elec	6 F32T8/841	2,800	16,800	0.87	14,616	160	91
6L32T8-LP Elec	6 F32T8/841	2,800	16,800	0.77	12,936	144	90

General Notes

- Lamp/ballast system values shown are a general reference intended to supply a quick comparison of several common lamp/ballast systems, the associated energy consumption, and net lumen output.
- Values shown are based on normal operating temperatures and at 277 volts.
- Fixture efficiency percentages are generally representative of each system type, actual values will vary.
- There are many operating variables that affect system output, in addition to rating variances from brand to brand.
- All T8 electronic ballast values shown are based on Ultra Efficient (aka 3rd Generation) T8 ballasts.
- All T5 and T8 lamp values shown are for basic grade lamps. Extended life and higher lumen lamps types are available.
- In addition to those shown there are a wide variety of systems to choose from, each with distinct features and cost points.
- Please consult the lamp/ballast manufacturer's catalogs for the detailed information required to model your system.